

Protection Cover LIFTKET

Product information



LIFTKET protection cover protects electric chain hoist and also the chain box with the chain inside perfectly from weather influences such as sun, rain or wind. Thanks to the velcro fastener, assembly and disassembly are super easy. Chain hoists in climbing position and in standard position can be operated with the cover. Available in 2 different sizes.

... [Read more](#)

Material: High-quality, heavy-duty material

Protection Cover LIFTKET

Blueprint

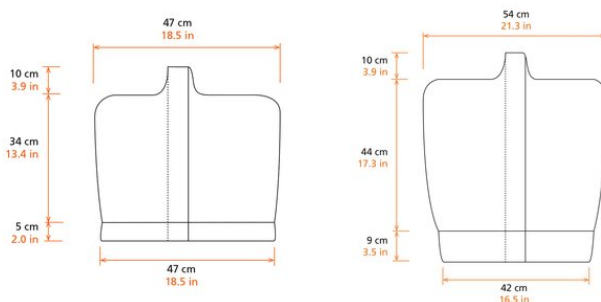

Technical data

Part code	Size	For hoist
5497770000300012	L	MODEL 05 and 07