

Portable Davit Crane 5PF5

Product information



225 kg capacity portable Davit Crane

- Load ratings up to 385 kg
- Portable, heaviest part 13,2 kg
- Rugged and affordable
- Manual or power winch operation (E2)
- 360° rotation
- Boom adjustable in three positions
- Easy, No-Tools Assembly/Disassembly (all individual components less than 13,5 kg)
- Variety of bases
- 2-Year warranty
- Proof of load 125% of WLL (Optional)

Machinery directive: 2006/42/EC as amended by Directive 95/16/EC.

[... Read more](#)

Marking: CE-marked

Finish: Powder coat

Note: Five corrosion-resistant surfaces (powder coating (5PT20), galvanized (5PT20G), stainless 304 (S) and 316 (S316) and three layers of epoxy)

Portable Davit Crane 5PF5

Blueprint

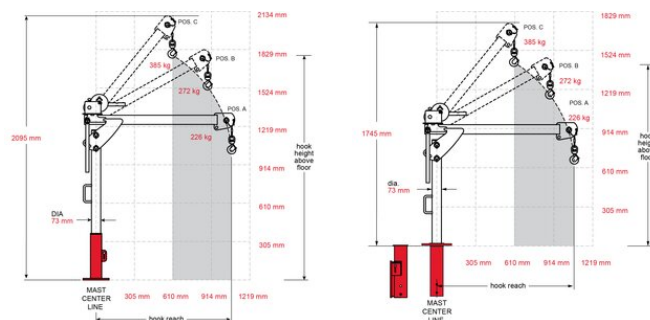

Technical data

Part code	Code	WLL ton	Weight kg
60115PF5	5PF5	0.23	2.5

First Mate, 5PF5, with Pedestal Base

Boom Position	Load Rating (KG)	Hook Reach (mm)	Hook height (mm)*
A	225	1066	1016
B	225	889	1524
C	225	609	1778

* Optional Base extension can provide 380mm more hook height

First Mate, 5PF5 with Flush or Wall base

Boom Position	Load Rating (KG)	Hook Reach (mm)	Hook height (mm)*
A	225	1066	660
B	225	889	1168
C	225	609	1422

* Optional Base extension can provide 380mm more hook height